

100100B X-RAY INSPECTION



Explosives, Weapons and Contraband

SINGLE SOURCE, MULTI-ENERGY

X-RAY INSPECTION



The 100100B direct transmission X-ray system features a raised conveyor that enables sharper, larger screen images while making loading and offloading easier. This heavy-duty conveyORIZED scanner is designed for screening large objects, hold baggage and cargo for concealed weapons, explosives and contraband. Multi-energy color allows operators to quickly spot areas of concern in the most thickly packed parcels, bulk loads and baggage.

- > Ideal for inspecting oversized and out-of-gauge objects
- > Produces larger, more detailed images
- > Excels in high throughput applications

APPLICATIONS:

- > Airports
- > Courts
- > Customs
- > Loading Docks
- > Mailrooms
- > Rail or Bus Stations
- > Government Buildings

100100B SPECIFICATIONS

X-RAY INSPECTION

PHYSICAL DETAILS

Tunnel Size:	100.0 x 100.0 cm 39.4 x 39.4 in. (W x H)
Dimensions:	314.2 x 129.3 x 192.9 cm 123.7 x 50.9 x 75.9 in. (L x W x H)
Weight:	726 kg (1,600 lbs.) uncrated 998 kg (2,200 lbs.) crated
Construction:	Unibody heavy gauge epoxy painted steel construction with stainless steel and aluminum trim and accessories; non-marking casters
Temperature:	0° to 40°C (32° to 104°F)
Humidity:	20% to 95%, non-condensing
Storage:	To 65°C (149°F)
Power Consumption:	< 0.7 kVA; < 7.5 amps 100, 110 volts AC ±10%; < 3.75 amps 200, 220, 240, 250 volts; all at 50 or 60 Hz

X-RAY GENERATOR

X-ray Tube Head:	Self-contained
High Voltage Rating:	160 kV
Duty Cycle:	100% with sealed oil bath cooling
Beam Orientation:	Diagonal (80° beam divergence)
Dose Per Exam:	0.1 mR

INSPECTION CAPABILITIES

Material Penetration:	28–29 mm (1.10–1.14 in.) steel
Contrast Sensitivity:	Over 2 million color tones standard
Resolution:	40 AWG wire
Processing:	32-bit adaptive image processing with minimum 1 Gbytes+ memory; 2.2GHz or 2.4 GHz+ dual core processor; video processing using next generation graphical processing unit architecture with 550MHz+ GPU clock, 512Mbyte+ video memory and 32+ stream processing cores
Conveyor Speed:	24.0 cm (9.4 in.) per second 14.6 m (48 ft.) per minute
Pulling Weight:	150 kg (331 lbs.)
Film Safety:	Guaranteed for high-speed film up to ISO 1600 (33 DIN)

DETECTORS

L-shaped detector for 100% object screening
Surface mounted, multilayer, fully integrated, high frequency solid state detectors using high speed processors and Pentium 4 image processing

VIDEO

Color 19" monitor, 1280 x 1024 video card

STANDARD FEATURES

- autoSoft operating system
- Full-size operator control panel (OCP) with touchpad navigation
- autoTracking guided conveyor belt system
- Reversible conveyor direction
- High/low density and stripping
- Organic/inorganic stripping
- Color; reverse B/W imaging
- Interactive, user-friendly help screens
- 128x Smart Zoom
- D-SCAN
- Dark and light enhance
- autoImage recall (10 images)
- RealClear
- autoDensAlert
- autoOutline
- autoSensing
- Z-SCAN
- autoCal
- Save screen to USB
- Adjustable zoom preview window

OPTIONS

- Loading or exit rollerbeds
- Tropical humidity kit
- DVD drive
- Dual conveyor motors
- autoMatAlert
- autoZ display
- Image archiving (500K)
- Threat image projection (TIP)
- Built-in training
- Level 1, 2 and 3 networking
- Item counter
- Remote operation
- autoArchive
- User management
- Locking metal OCP cover
- Dual and larger monitors
- Locking monitor garage
- Laser printer
- Console desk
- kV, mA meter
- Power conditioner, or UPS
- Optical X-ray on/off sensor
- Footpad
- STI Viewer software for archived image analysis

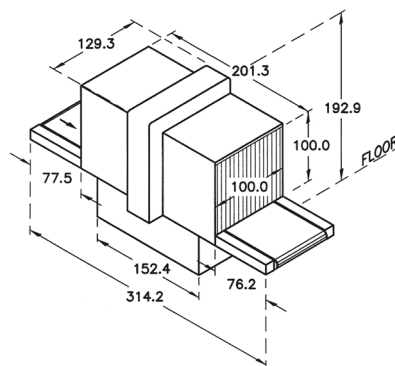

NOTE: Non-marking casters. Dimensions are in centimeters.